

Technical sheet

# **MLT-X 625 75 H**

Telehandlers



Capacities	Metric	Imperial
Max. capacity	2500 kg	5512 lbs
Max. lifting height	5.90 m	19 ft 5 in
Max. outreach	3.30 m	10 ft 11 in
Reach at max. height	0.50 m	1 ft 7 in
Breakout force with bucket	4205 daN	-
Weight and dimensions		
Unladen weight (with forks)	4922 kg	10851 lbs
m4 - Ground clearance	0.38 m	2 in
l2 - Overall length to carriage (with hitch)	3.90 m	12 ft 11 in
y - Wheelbase	2.30 m	7 ft 7 in
b4 - Overall width of cab	0.80 m	2 ft 8 in
b1 - Overall width	1.81 m	5 ft 1 in
h17 - Overall height	2 m	6 ft 7 in
a4 - Crowd angle	12 °	12 °
a5 - Dump angle	117 °	117 °
Wa1 - External turning radius (over tyres)	3.31 m	10 ft 1 in
Standard tyres	300/75 R18 A580 - Alliance	300/75 R18 A580 - Alliance
Performances		
Lifting	7.30 s / -	7.30 s / -
Lowering	4.95 s / -	4.95 s / -
Extension	5.20 s / -	5.20 s / -
Retraction	3.70 s / -	3.70 s / -
Crowd	3.20 s	3.20 s
Dump	3.20 s	3.20 s
Engine		
Brand	Kubota	Kubota
Environmental norm	Stage 3A	Stage 3A
Number of cylinders - Cubic capacity	4 - 3331 cm <sup>3</sup>	4 - 204 in <sup>3</sup>
Power	75 hp / 55.40 kW	75 hp / 55.40 kW
Max. torque	265 Nm at 1400 rpm	195 ft.lbs at 1400 rpm
Reversible fan	Standard	Standard
Cooling system	2 radiators (water + hydraulic oil)	2 radiators (water + hydraulic oil)
Transmission		
Type	Hydrostatic	Hydrostatic
Number of gears (forward/reverse)	2	2
Max. travel speed (may vary according to applicable regulations)	25 km/h	16 mph
Differential lock	Limited slip differential on front axle	Limited slip differential on front axle
Parking brake	Automatic negative parking brake	Automatic negative parking brake
Service brake	Hydraulic oil immersed multi-disc braking on front axle	Hydraulic oil immersed multi-disc braking on front axle
Hydraulics		
Hydraulic pump type	Gear pump	Gear pump
Hydraulic flow - Pressure	90 l/min - 235 bar	23.77 gpm - 3408 psi
Tank capacities		
Hydraulic oil	115 l	30 US gal.
Fuel	63 l	17 US gal.
Noise & vibration		
Noise at driving position (LpA) tested following NF EN 12053 norm	76 dB(A)	76 dB(A)
Environmental noise (LwA)	104 dB(A)	104 dB(A)
Vibration to whole hand / arm	<2.5 m/s <sup>2</sup>	<8.2 ft/s <sup>2</sup>
Miscellaneous		
Safety controls	EN 15000 Norm Cab ROPS - FOPS Level 1  JSM	EN 15000 Norm Cab ROPS - FOPS Level 1  JSM

## Options / Finishing

S : Standard / O : Optional / - : Not available

	Classic	Premium	Elite
<b>General</b>			
Self cleaning air prefilter	S	S	-
Auto reversing fan	S	S	-
Hand throttle with engine memo	O	O	-
Manual rotating towing hitch	O	O	-
<b>Comfort</b>			
Tuner car radio (50 W)	S	-	-
Manual air conditioning	O	S	-
Rear windscreen defrost	O	O	-
<b>Hydraulic</b>			
Continuous flow hydraulics	O	O	-
Easy Connect System (ECS)	O	S	-
Attachment hydraulic locking	O	O	-
Electrovalve for 2 hydraulic functions (on boom head)	O	O	-
Return pipe to hydraulic oil tank	O	O	-
<b>Electricity / Safety</b>			
Audio warning on reverse movements	O	O	-
Electric predisposition on boom	O	O	-
Poultry farming blue lights	O	O	-

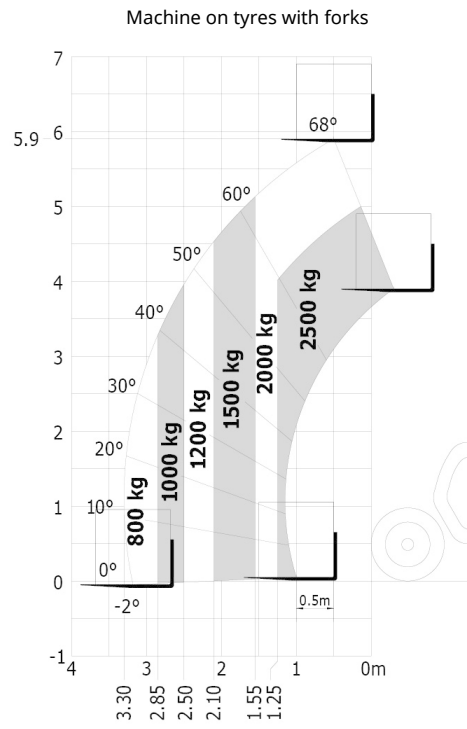

Rough terrain load chart (EN 1459 B)

Dimensional drawing

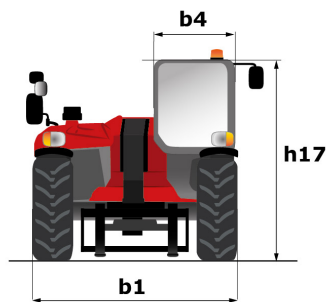
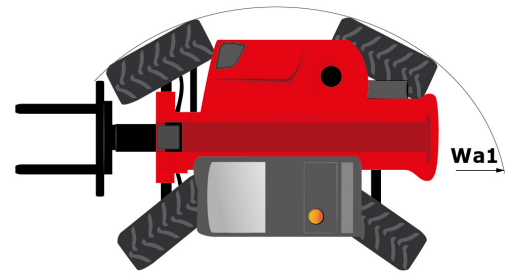
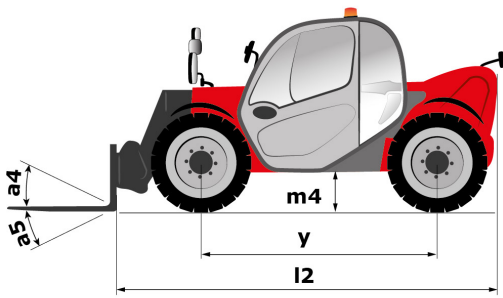

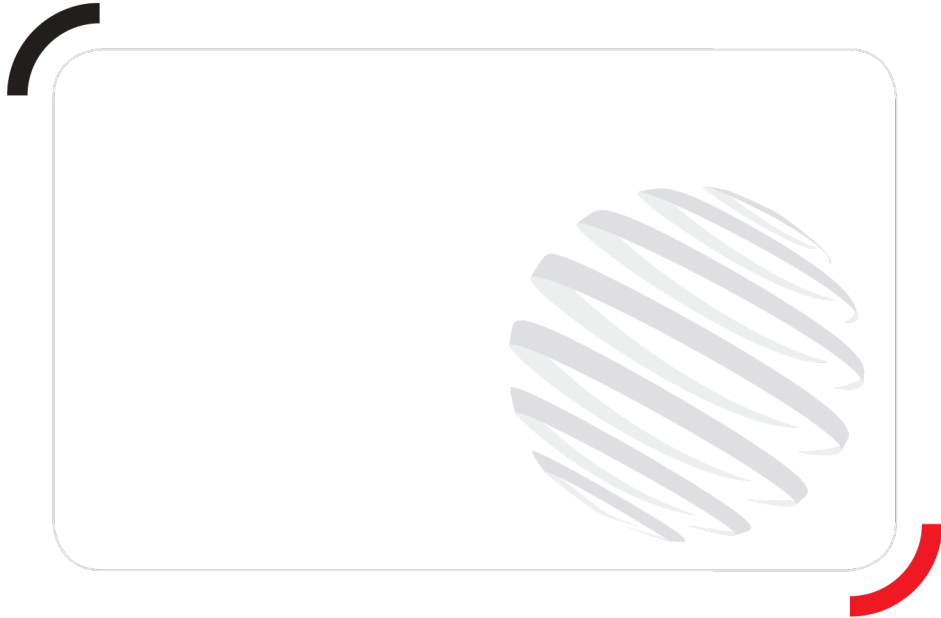

Siège Social  
430 rue de l'Aubinière - 44150 Ancenis Cedex - France  
Tel: +33(0)2 40 09 10 11 - Fax: +33 (0)2 40 09 10 97  
[www.manitou.com](http://www.manitou.com)



This brochure describes versions and configuration options for Manitou products which may be fitted with different equipment. The equipment described in this brochure may be standard, optional or not available depending on version. Manitou reserves the right to change the specifications shown and described at any time and without prior warning. The manufacturer is not liable for the specifications given. For more information, contact your Manitou dealer. Non-contractual document. Product descriptions may differ from actual products. List of specifications is not comprehensive. The logos and visual identity of the company are the property of Manitou and may not be used without authorisation. All rights reserved. The photos and diagrams contained in this brochure are provided for information only.

MANITOU BF SA - Limited company with board of directors - Share capital: 39,547,824 euros - 857 802 508 RCS Nantes